

Installation Instructions For:
ST90CPB-P-70
ST90CPB-S-70

90mm x 50mm WATER SEAL SHOWER TRAP

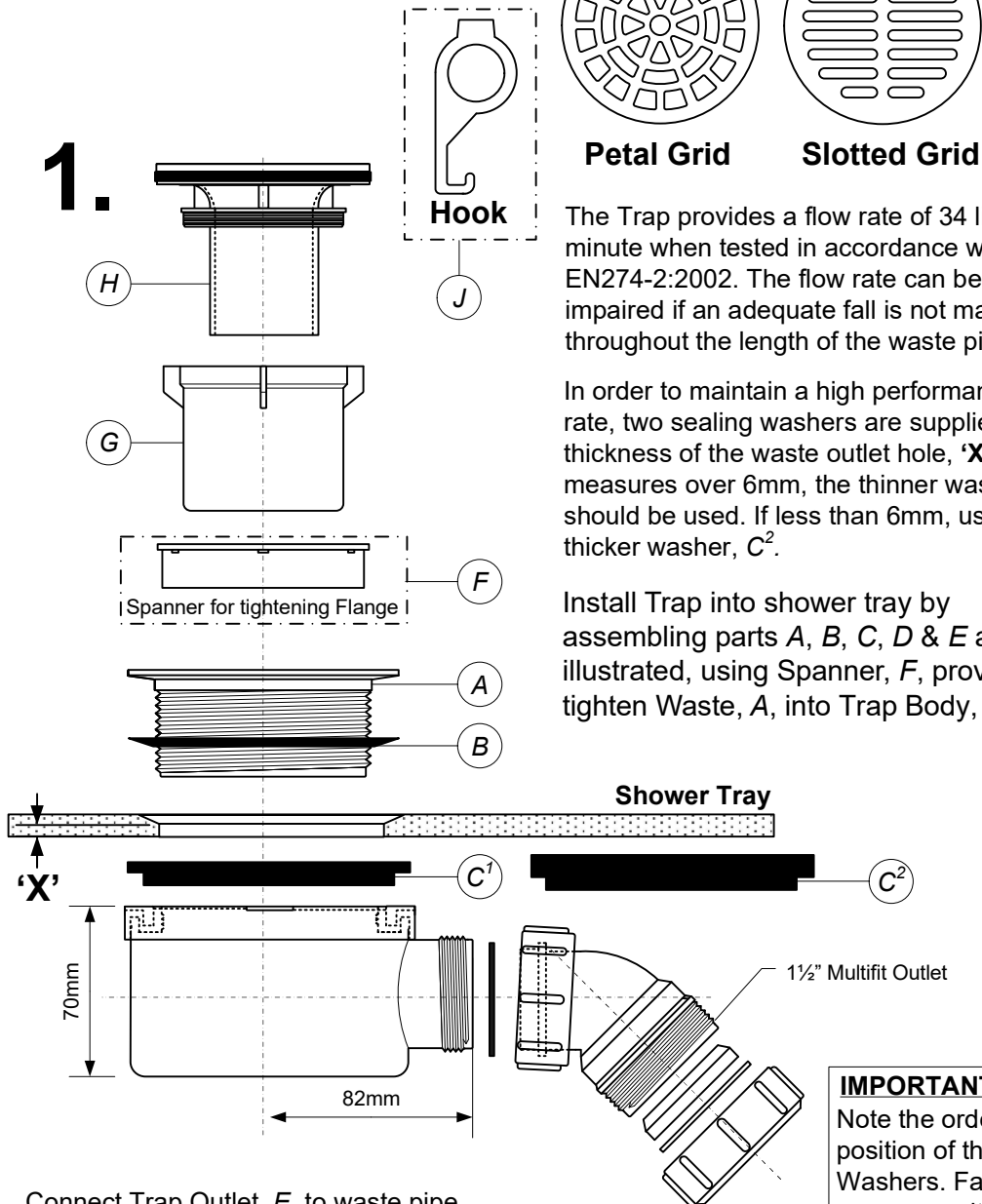

1.



The Trap provides a flow rate of 34 litres per minute when tested in accordance with EN274-2:2002. The flow rate can be seriously impaired if an adequate fall is not maintained throughout the length of the waste pipe.

In order to maintain a high performance flow rate, two sealing washers are supplied. If the thickness of the waste outlet hole, 'X', measures over 6mm, the thinner washer, C¹, should be used. If less than 6mm, use the thicker washer, C².

Install Trap into shower tray by assembling parts A, B, C, D & E as illustrated, using Spanner, F, provided to tighten Waste, A, into Trap Body, D.

Connect Trap Outlet, E, to waste pipe, ensuring that the pipe is adequately supported. Test the installation.

IMPORTANT:
 Note the order and position of the Sealing Washers. Failure to do so can result in water leakage.

2.

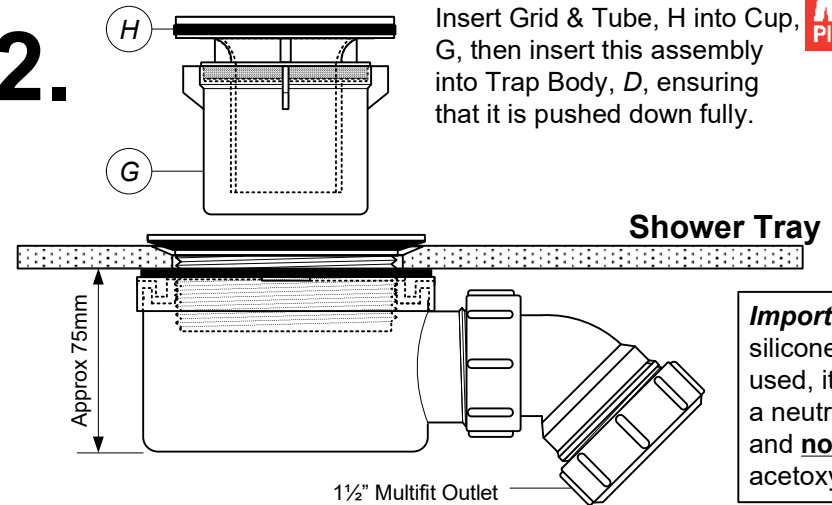

Insert Grid & Tube, H into Cup, G, then insert this assembly into Trap Body, D, ensuring that it is pushed down fully.

Important: If a silicone sealant is used, it should be a neutral sealant and **not** an acetoxy sealant.

3. **Completed Assembly**

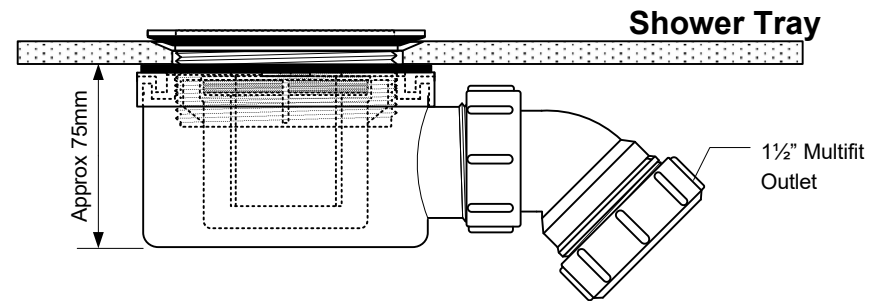

After Care:

Regular maintenance is essential to retain a high performance flow rate. Remove the Grid and Tube Assembly, G&H, using the supplied Hook, J, and thoroughly clean all the parts. Flush through the Trap Body with clean water and carefully replace the parts.

